

Tubular Handles

Stainless Steel, with Movable Handle Legs, Hygienic Design



NV 24102



SPECIFICATION

- Handle tube
Stainless steel AISI 304 **NI**
- Ground, matte finish ($R_a < 0.8 \mu\text{m}$) **MT**
- Handle legs
Stainless steel AISI 304
Matte finish ($R_a < 0.8 \mu\text{m}$)
- Sealing ring and wiper
TPU **T**
- Temperature resistant -20°C to $+110^\circ\text{C}$
- FDA compliant material
- Blue
- Hardness 95 ± 5 Shore A
- Clamping wedge
Brass
- Grub screw
Stainless steel

INFORMATION

Tubular handles GN 3330 comply with the DGVU testing principles and are designed for use in hygienic areas. The sealed mounting surface enables fastening without dead spaces. The high quality finish as well as the non-concave geometry prevent adherence of dirt and facilitate cleaning.

The handle legs are loosely enclosed for fastening to the handle tube using the integrated clamping wedge during installation. The position of the handle legs can be adjusted as required, but must not be less than the minimum distance a , as the tubes may be undersized in the edge area.

For large lengths or loads, additional handle legs can be added. These are available under standard part number GN 3331 (see page).

ACCESSORY

- Screws GN 1580 (see page)
- Screws GN 1581 (see page)
- Handle Legs GN 3331 (see page)

TECHNICAL INFORMATION

- Plastic Characteristics (see page A2)
- Stainless Steel Characteristics (see page A26)

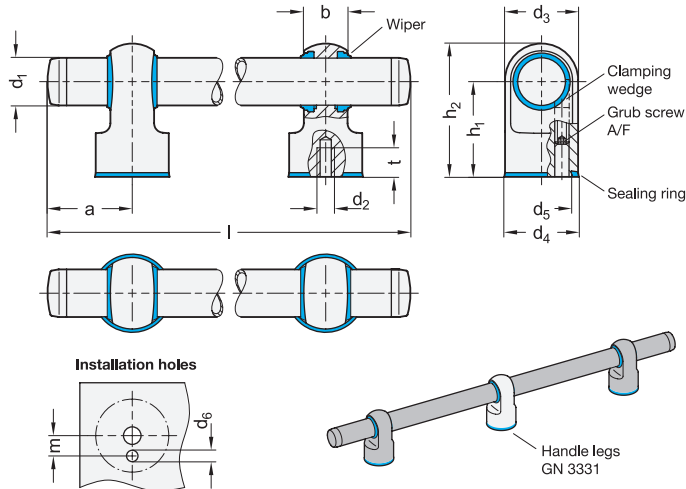

GN 3330

STAINLESS STEEL

Description	d1	Length l	a min.	b	d2	d3	d4	d5	d6	h1	h2	m	A/F	t min.	Δ
GN 3330-NI-30-300-MT-T	30	300	70	27.5	M10	46	46.6	42	8	60	84	13.5	5	20	1687
GN 3330-NI-30-400-MT-T	30	400	70	27.5	M10	46	46.6	42	8	60	84	13.5	5	20	1793
GN 3330-NI-30-500-MT-T	30	500	70	27.5	M10	46	46.6	42	8	60	84	13.5	5	20	1900
GN 3330-NI-30-600-MT-T	30	600	70	27.5	M10	46	46.6	42	8	60	84	13.5	5	20	2005
GN 3330-NI-40-400-MT-T	40	400	70	30	M12	56	56.8	50	8	70	99	18.5	5	25	2803
GN 3330-NI-40-600-MT-T	40	600	70	30	M12	56	56.8	50	8	70	99	18.5	5	25	3090
GN 3330-NI-40-800-MT-T	40	800	70	30	M12	56	56.8	50	8	70	99	18.5	5	25	3376
GN 3330-NI-40-1000-MT-T	40	1000	70	30	M12	56	56.8	50	8	70	99	18.5	5	25	3663

